

Overvoltage in solar power system due to nearby lightnings

Author

Hossain, MA, Ahmed, MR

Published

2015

Journal Title

Journal of Electrical Engineering

Version

Version of Record (VoR)

Rights statement

© The Author(s) 2015. This article is an open access article distributed under the terms and conditions of the Creative Commons Attribution (CC BY) license (<http://creativecommons.org/licenses/by/4.0/>), which permits unrestricted use, distribution, and reproduction in any medium, provided the original work is properly cited.

Downloaded from

<http://hdl.handle.net/10072/412112>

Link to published version

<http://www.jee.ro/index.php/jee/article/view/WK1409476379W5402e71b01d73>

Griffith Research Online

<https://research-repository.griffith.edu.au>

See discussions, stats, and author profiles for this publication at: <https://www.researchgate.net/publication/276145219>

Overvoltage in solar power system due to nearby lightnings

Article in *Journal of Electrical Engineering* · January 2015

CITATIONS

3

READS

804

2 authors:



Md. Alamgir Hossain
Griffith University

72 PUBLICATIONS 926 CITATIONS

[SEE PROFILE](#)



Md. Raju Ahmed
Dhaka University of Engineering & Technology

46 PUBLICATIONS 272 CITATIONS

[SEE PROFILE](#)

Some of the authors of this publication are also working on these related projects:



Improved Load Frequency Control [View project](#)



Design and Analysis of Bagasse, Coal and Biogas Based Optimum Cogeneration for Sugar Mills in Bangladesh [View project](#)

OVERVOLTAGE IN SOLAR POWER SYSTEM DUE TO NEARBY LIGHTNINGS

MD. ALAMGIR HOSSAIN and MD. RAJU AHMED

Department of Electrical & Electronic Engineering
Dhaka University of Engineering & Technology (DUET)
Gazipur-1700, Bangladesh
Email: alamgir_duet@hotmail.com

Abstract— Solar power generation is increasing dramatically because of environmental friendly and available energy source compared to other renewable energy sources. One of the major threats of expansion of solar power system is lightning damage. So, the induced voltage on power condition system (PCS) of solar power system due to different places of nearby lightning strike is analyzed using electromagnetic field analysis approach, and the cause of damage of system is investigated. It is found that the maximum induced voltage change per unit distance is observed 5kV changing strike point vertically from the prescribed point, and minimum voltage is observed for horizontal changes. In addition, the induced voltage is found excessive at high rate of rise time of lightning strike currents. The induced voltage is studied with the help of FDTD method. Virtual Surge Test Lab (VSTL) is used for FDTD calculations, which solve Maxwell's electromagnetic equations with minimum approximations. The model of solar power system was represented with thin wire, which is a good approximation of power line and steel frame.

Key words: Induced voltage, indirect lightning strike, solar power system, different lightning points

1. Introduction

Power generation by solar panel is increasing sharply in Bangladesh because of instinctive installation of panel, cost effectiveness, and getting continuous power. Bangladesh has a plan to produced power commercially by solar panel in near future due to dearth of conventional energy sources [1, 2]. Therefore, it is encouraged to install solar panel to produce power from solar radiation. This growth can be maintained with proper investigation of protection system for solar panel.

Lightning induced overvoltage in the line of solar panel can be cause of damaging photovoltaic generator and its supplementary electrical and electronic equipment in the operating system [3]. In the case of large solar power system, which is installed in the field under the open sky, there is a possibility of inducing high voltage in the DC line of photovoltaic panel due to lightning that leads to the damage of PCS equipment and/or junction box [3].

The knowledge of induced voltage of an engineer can protect the solar panel and its ancillary equipment from destruction of a system.

In numerous researches, lightning induced phenomena has been considered intensively [4-7], and it was found its typical behavior, although specific problems are not anticipatable for particular incidents. Lightning induced voltage on solar power system was investigated in Yokoyama and Benesova work [8, 9]. They concluded that lightning voltage is proportional to peak value of lightning current. M Hossain and Ahmed [10-12] have shown lightning induced voltage in between line to line is proportional to the object height on which lightning has stroked, and also demonstrated underground cable is compatibly less affected than on ground cable. Mourad has investigated the induced voltage of solar power system by direct strike on solar panel and has found line to PCS voltage is 1000kV at resistivity 100Ωm [13]. In his study, it was recommended to use arrester in the lines to protect the PV panel. In order to enhance the solar protection system, lightning induced voltages is necessary for further study to design solar power system for secure, reliable, and economical operation.

In practical situation, most of the incident occurred in the system was identified due to indirect lightning effect [14]; therefore, it suggests that the indirect lightning effect should study rigorously to design a system appropriately. In Japan, it is found that 24.8% of the overall PV system has been damaged due to lightning effect [15]. The lightning induced phenomena mainly depend upon the velocity of electromagnetic field of return stroke along the striking line [16-18].

The computations were done using the 3-Dimensions finite difference time domain (FDTD) method [19] which solves the Maxwell's equations directly. This method can effortlessly handle dielectrics and conductors, and is applied to surge analysis in many fields [14, 17]. Induced voltages of horizontal wires were calculated by integrating the electric field from the ground plane to the conductor

height. In this paper, DC wire and frame of solar panel is represented with thin wire model [20], and frequency dependency of soil is not considered. This paper analyzed the induced voltage of line to PCS and line to line due to nearby lightning distance changes. For more comprehension, this paper is divided into mainly 3 parts where 1st part describes methodology, 2nd part illustrates modeling and simulating of solar power system, and last part discusses the results of simulation.

2. Analysis Methodology

Virtual Surge Test Lab (VSTL) [21, 22], which was developed by Central Research Institute of Electric Power Industry (CRIEPI), code used FDTD method to solve electromagnetic surge related propagation problems. The VSTL code is verified with practical values in numerous papers [21] [23, 24]. The VSTL code is capable of handling non-linear elements and thin conductor, which are difficult task in the FDTD method. The results of this software depend on total space, cell size, time step, and boundary condition. It represents physical and geometrical mean rather than circuit. The cell size in this method should not surpass $\lambda/10$, where λ is the wavelength corresponding to the highest frequency in the excitation.

Electric field and magnetic field are calculated as the root-mean-square value of the two tangential components and as the absolute value of the normal component in the section respectively. The voltage difference can be defined across a side of the cell as $V=E\Delta s$, because waves of which the wave length is shorter than $\lambda=2\Delta s$ do not present in the FDTD calculation due to the bandwidth limitation of Δs . Induced voltages of horizontal wire were computed by integrating the electric field from the ground plane to the conductor height, and current is calculated by applying Ampere's Law which gives relation between current and magnetic field.

Lightning stroke channel ensuring a return stroke current ($0.25/100\mu s$) with magnitude 50kA, recommended by IEC [25] keeping propagation velocity of return stroke is 1/3 of the speed of light [26, 27], is represented by engineering model built in VSTL.

3. Analysis Model

Fig. (1 and 2) shows analytical model of indirect lightning effect on solar system in VSTL; where height, width, and length of solar panel are 2.5m, 3m, and 20m respectively. Power Conditioning Subsystem (PCS) is placed 17m away from the solar panel with 30m long insulated DC cables. Cables are insulated by 0.1m thickness having relative permittivity 3, separated by 0.1m, and placed under 1m depth of surface ground. Analysis space in the VSTL was taken $35\times 35\times 30m$ in the X, Y, and Z direction respectively. Soil is considered up to 10m

of Z direction with resistivity $50\Omega m$ and relative permittivity 10. Liao's second order absorbing boundary condition was established in the six planes of analysis space to represent as infinite space [28]. Cell size is 10cm in the focusing point of analysis space and increased up to 1m.

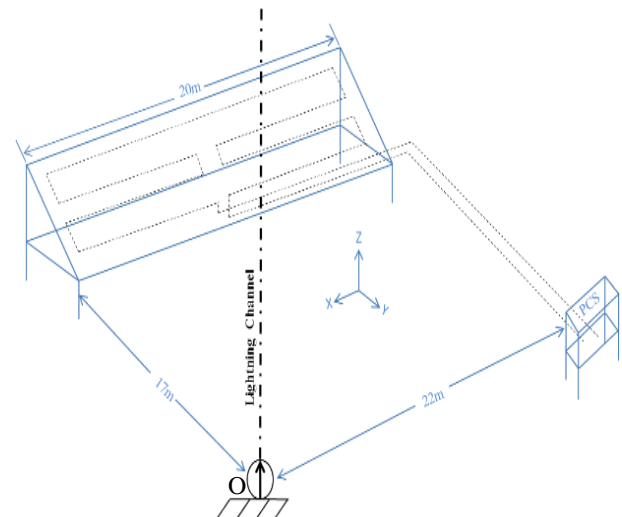

Figure 1 Solar power system and lightning channel analytical model in VSTL

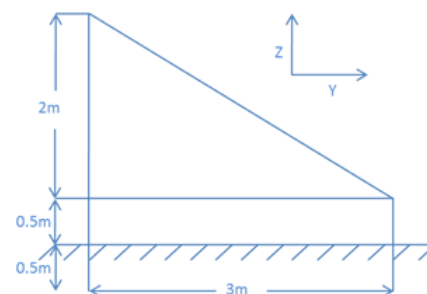

Fig. 2 Dimensions of solar panel installation

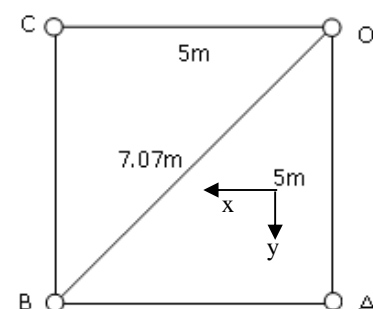

Fig. 3 Strike points of lightning, point "O" is situated in lightning channel shown in Figure 1

Fig. 3 illustrates that lightning strike points for analyzing the induced voltage on DC cables of solar power system. The point "O" is considered 17m away from the solar panel and 22m apart from the DC cables.

4. Result and Discussion

Lightning induced voltage of a conductor depends on lightning points stroked at nearby places. In our analysis, lightning point was considered four places to observe each effect of lightning on DC cables. The knowledge of induced voltage due to lightning can protect the system from damaging by using particular shield. Therefore, we examine in our study, how the lightning induced voltage is changed with respect to different strike points and change of rise time of lightning current.

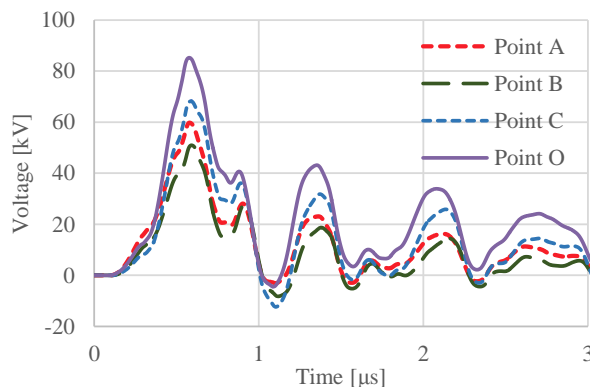

Fig. 4 Line to PCS induced voltage

Fig. 4 interprets line to PCS lightning induced voltage due to several lightning strike places indicated in the Fig. 3. It is shown that lightning induced voltage is found highest at strike point O, and its maximum magnitude is 84.91kV at 0.587 μ s with oscillation frequency 3.28MHz. Lightning stroke at point C is found the next highest magnitude, 68.14kV, at 0.58 μ s. The stroke point A and B are result of the two lower magnitudes induced line to PCS voltage, as well as its effect on induced voltage is observed 59.91kV and 50.90kV at time 0.54 μ s and 0.59 μ s respectively. The induced voltage of line to PCS is varied due to horizontal strike point shift from point O to C is 3.354kV/m. Due to vertical point shift from point O to A, the induced voltage is altered with 5kV/m. The induced voltage per unit distance from point O to point B is 4.81kV. It can be concluded that with the moving vertical distance from point O, the induced voltage is obtained in high decreasing form among other points. The next lower value is observed along diagonal of square points. The lowest reduction is observed for shifting distance horizontally.

It is observed, in Fig. 5, that the line to line voltages at panel wiring side have no significant changes in magnitude. The maximum induced voltage was recorded at point C is 15.46kV at 2.4 μ s with oscillation frequency 12.52MHz.

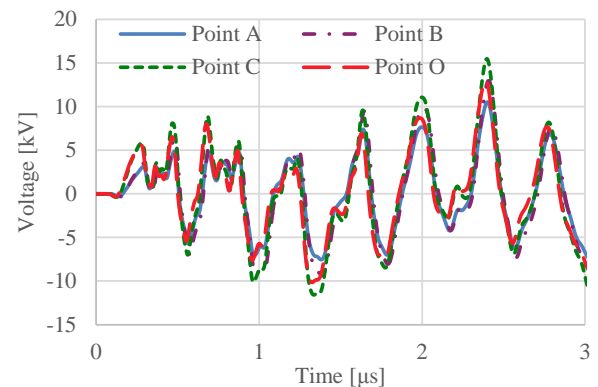

Fig. 5 Line to line voltage at panel wiring side

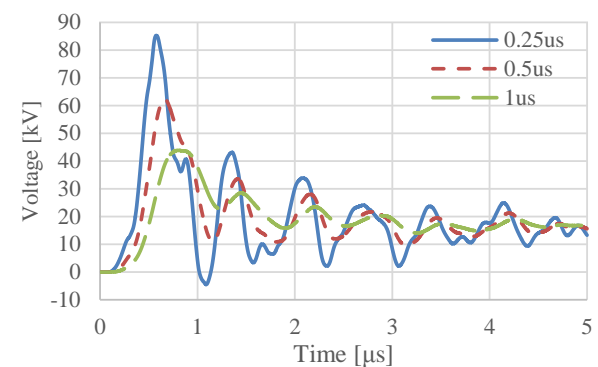

Fig. 6 Line to PCS induced voltage due to different lightning rise time

Fig. 6 indicates the change of induced voltage for different current rise time in the lightning channel model. It is noticed that shortest rise time injected current produce high induced voltage with highest oscillation frequency in the line and this value is approximately 85.197kV at time 0.574 μ s with oscillation frequency 7.55MHz for 0.25 μ s rise time. The next induced voltage is beheld for 0.5 μ s is 62.42kV at 0.67 μ s, where oscillation frequency is 1.61MHz. For rise time of 1 μ s, the induced voltage at 0.81 μ s is 43.84kV having oscillation frequency 1.52MHz.

5. Conclusion

The knowledge of lightning induced overvoltage in DC cable can solve the specific problems of solar power system. The study demonstrates the minimum lightning induced voltage change per unit distance change is 3.354kV when the lightning strike point is shifted horizontally from O to C and the maximum induced voltage change per unit distance is observed 5kV shifting strike point vertically from point O to A. It is also observed that the short rise time lightning current produce high induced voltage in the DC cables which was measured for 0.25 μ s is 85.2kV. It is recommended to install surge protection device in the lines to reduce such high voltage for uninterrupted operation.

6. References

- [1] M. A. Hossain and M. R. Ahmed, "Present energy scenario and potentiality of wind energy in Bangladesh," *World Academy of Science, Engineering and Technology*, vol. 7, no. 11, pp. 785-791, 2013.
- [2] M. A. Hossain, M. Z. Hossain, and M. A. Rahman, "Perspective and challenge of tidal power in Bangladesh," *World Academy of Science, Engineering and Technology*, vol. 8, no. 7, pp. 1040-1043, 2014.
- [3] C. A. Nucci, F. Rachidi, M. Ianoz and C. Mazzetti, "Lightning-induced voltage on overhead lines," *IEEE Trans. on Electromagnetic Compatibility*, vol. 35, no. 1, pp. 75-86, 1993.
- [4] H. Stern and H. C. Karner, "Lightning Induced EMC phenomena in photovoltaic," in *IEEE International Symposium on Electromagnetic Compatibility 1993*, 1993.
- [5] V. Rakov, M. Uman, M. Fernandez, C. Mata, K. Rambo, M. Stapleton and R. Sutil, "Direct lightning strikes to the lightning protective system of a residential building: Triggered lightning experiments," *IEEE Trans. on Power Delivery*, vol. 17, no. 2, 2002.
- [6] P. Hasse, *Overvoltage protection of low voltage systems*, 2nd edition ed., London IEE press.
- [7] F. A. M. Rizk, "Modeling of transmission line exposure to direct lightning strokes," *IEEE Trans. on Power delivery*, vol. 5, no. 4, pp. 1983 - 1997, 1990.
- [8] S. Yokoyama, K. Miyake, H. Mitani and A. Takanishi, "Simultaneous measurement of lightning induced voltages with associated stroke currents," *IEEE Trans. on Power Apparatus and Systems*, Vols. PAS-102, no. 8, pp. 2420-2429, 1983.
- [9] Z. Benesova, R. Haller, J. Birkl and P. Zahlmann, "Overvoltages in photovoltaic systems induced by lightning strikes," in *2012 International Conference on Lightning Protection (ICLP)*, 2012.
- [10] M. A. Hossain and M. R. Ahmed, "Analysis of lightning induced overvoltage in DC line of solar power panel," in *National Conference on Electronic for Digital*, Dhaka, 2014.
- [11] M. A. Hossain and M. R. Ahmed, "Study and protection of lightning overvoltage on DC cables of solar power generation," in *2014 International Conference on Electrical and Computer Engineering (ICECE)*, pp.325-328, Dhaka, 2014.
- [12] M. A. Hossain and M. R. Ahmed, "Analysis of indirect lightning phenomena on solar power system," *Journal of Electrical Engineering*, Vol. 14, no. 4, 2014.
- [13] M. E. Azhari, "Lightning -induced voltage on DC power line of PV panel," *Masters Thesis*, University of Tokyo, 2013.
- [14] Uman, M A. *All About Lightning*, Toronto: Dover, 1986, pp. 1-158.
- [15] "Technical analysis and evaluation activities related to the status of measures to reduce lightning damage of photovoltaic systems," *New Energy and Industrial technology Development Organization (NEDO)*, 2009.
- [16] C. D. Taylor, R. S. Satterwhite and C. W. Harrison, "The response of a terminated two-wire transmission line excited by nonuniform electromagnetic field," *Vols. AP-13, IEEE Trans. on Antennas Propag.*, 1965, p. 987-989.
- [17] F. Rachidi, "Formulation of the field to transmission line coupling equations in terms of magnetic excitation fields," *IEEE Trans. on Electromagn. Compat.*, vol. 35, no. 3, p. 404-407, 1990.
- [18] A. K. Agrawal, P. H. J and S. H. Gurbaxani, "Transient response of multiconductor transmission lines excited by a nonuniform electromagnetic field," *IEEE Trans. on Electromagn. Compat.*, Vols. EMC-22, no. 3, p. 119-129, 1980.
- [19] K. Yee, "Numerical solution of initial boundary value problems involving Maxwell's equations in isotropic material," *IEEE Transactions on Antennas and Propagation*, vol. 14, no. 3, pp. 302-307, 1966.
- [20] T. Noda and S. Yokoyama, "Thin wire representation in finite difference time domain surge simulation," *IEEE Trans. on Power Delivery*, vol. 17, no. 3, pp. 840-847, 2002.
- [21] S. Yokoyama and T. Noda, "Development of general surge analysis program based on the FDTD method," *Trans. IEE of Japan*, Vols. 121-B, no. 5, pp. 625-632, 2001.
- [22] T. Noda, A. Tatematsu and S. Yokoyama, "Improvements of an FDTD-based surge simulation code and its application to the lightning overvoltage calculation of a transmission tower," in *Proc. Int. Conf. on Power Systems Transients (IPST)-2005*, Montreal, Canada..
- [23] K. Tanabe, A. Asakawa, M. Sakae, M. Wada and H. Sugimoto, "Verifying the computational method of transient performance with respect to grounding systems based on the FDTD method," *IEEJ Trans. on Power and Energy*, vol. 123, no. 3, p. 358-367, 2003.
- [24] T. Noda, "A tower model for lightning overvoltage studies based on the result of an FDTD simulation," *IEEJ Trans. on Power and Energy*, Vols. 127-B, no. 2, pp. 379-388, 2007.
- [25] "Protection against lightning - Part 1: General Principles," *IEC 62305-1:2006-01*, 2006.
- [26] B. F. J. Schonland, "The Lightning Discharge," *Handbuch der Physik*, vol. 22, pp. 576-628, 1956.
- [27] V. P. Idone and R. E. Orville, "Lightning return stroke velocities in the thunderstorm research international program (TRIP)," *Journal of Geophysical Research*, vol. 87, no. C7, pp. 4903-4915, 1982.
- [28] Z. P. Liao, H. L. Wong, B. P. Yang and Y. F. Yuan, "A transmitting boundary for transient wave analyses," *vol. A27*, no. 10, p. 1063 - 1076, 1984.