

Design equations for tensile rupture resistance of bolted connections in cold-formed steel members

Author

Teh, LH, Gilbert, BP

Published

2014

Conference Title

22nd International Specialty Conference on Recent Research and Developments in Cold-Formed Steel Design and Construction

Version

Version of Record (VoR)

Rights statement

© The Author(s) 2014. The attached file is reproduced here in accordance with the copyright policy of the publisher. For information about this conference please refer to the conference's website or contact the authors.

Downloaded from

<http://hdl.handle.net/10072/163329>

Link to published version

<http://ccfsonline.org/international-specialty-conference/>

Griffith Research Online

<https://research-repository.griffith.edu.au>

Design Equations for Tensile Rupture Resistance of Bolted Connections in Cold-Formed Steel Members

Lip H. Teh¹ and Benoit P. Gilbert²

Abstract

This paper summarises and re-examines the authors' previous research results concerning the tensile rupture resistance of cold-formed steel bolted connections in a flat sheet, in a channel's web, and in one leg of an angle section. Staggered bolted connections are also included. The fundamental shortcomings of the design equations given in the 2012 North American Specification for the Design of Cold-formed Steel Structural Members are described, and the alternative design equations proposed by the authors are shown. The alternative equations are checked against laboratory test results obtained by the authors and other researchers where the bolts had not been snug-tightened and the failure modes were correctly identified. The reliability analyses previously carried out by the authors are repeated using additional test data and the statistical data provided in the current North American specification. A uniform resistance factor of 0.70 is recommended for all the proposed equations for determining the tensile rupture resistance of bolted connections in cold-formed steel members.

Introduction

Section E6.2 of the North American Specification for the Design of Cold-formed Steel Structural Members (AISI 2012) provides the design equations for determining the tensile rupture resistance of bolted connections in a flat sheet, in a channel's web, and in one leg of an angle section. It also provides same for staggered bolted connections in a flat sheet. These equations have remained largely unchanged from the earlier specification (AISI 2010), and have been

¹ Senior Lecturer, School of Civil, Mining & Environmental Engineering, University Of Wollongong, Wollongong, NSW 2500, AUSTRALIA.

² Senior Lecturer, School of Engineering, Griffith University, Gold Coast, QLD 4222, AUSTRALIA.

shown by Teh & Gilbert (2012, 2013a, 2013b) and Teh & Clements (2012) to have rooms for necessary and significant improvements.

Teh & Gilbert (2012, 2013a, 2013b) and Teh & Clements (2012) proposed alternative design equations that were free from anomalies. The alternative equations were found to be consistently accurate for laboratory test specimens composed of 1.5-mm and 3.0-mm G450 sheet steels, which either satisfied or missed the specification's material ductility requirements marginally. However, except for Teh & Gilbert (2013b), Australian statistical data were inadvertently used in computing the resistance factors from Section F1.1 of the AISI specification. Strictly speaking, the statistical data provided in Table F1 of the specification (AISI 2012) should be used.

In any case, for the purpose of determining the resistance factor of a design equation, it is ideal to include the test results obtained by independent researchers, especially those involving steel materials having different levels of ductility. In the present work, the equation proposed by Teh & Gilbert (2012) for determining the tensile rupture resistance of a bolted connection in a flat sheet is therefore checked against the laboratory test results of Rogers & Hancock (1997), while the equation proposed by Teh & Gilbert (2013a) for determining the tensile rupture resistance of a channel brace bolted at the web is checked against the laboratory test results of Pan (2004).

Rogers & Hancock (1997) ensured that each bolt was tightened to a torque less than 10 Nm only to avoid significant frictional resistance. On the other hand, some researchers had applied tightening torques of 100 Nm or greater (eg. Paula et al. 2008). In many published studies, the extent of bolt tightening was not reported, likely because the issue was not considered to be significant. However, as detailed by Teh & Yazici (2013), frictional resistance due to snug-tightening of bolts contributed significantly to the ultimate test loads of some specimens found in the literature, up to 30% (Yip & Cheng 2000). This paper therefore does not make use of the test results where the bolts had been snug-tightened in verifying the alternative design equations.

In addition to the problem due to snug-tightening of bolts, misidentifications of the failure modes of bolted connections have taken place in the literature. The misidentification of a bearing failure for a tensile rupture is relatively well-known (LaBoube 1988, Rogers & Hancock 2000), but there seems to have been misidentifications of block shear failures for net section tensile ruptures as well (Teh & Yazici 2013). Needless to say, specimens which did not fail in the net section tensile rupture mode are not included in the present study.

This paper summarises and re-examines the heuristic reasoning behind the equations proposed by Teh & Gilbert (2012, 2013a, 2013b) for determining the tensile rupture resistance of bolted connections in a flat sheet, in a channel's web, and in one leg of an angle section, and that proposed by Teh & Clements (2012) for a staggered bolted connection in a flat sheet. The previous reliability analyses are repeated using additional test data where applicable and the statistical data provided in the current North American specification (AISI 2012).

This paper concludes by proposing four design equations to be balloted for inclusion in the North American Specification for the Design of Cold-formed Steel Structural Members, along with the recommended resistance factors.

Tensile rupture resistance of a bolted connection in a flat sheet

Figure 1 shows the net section tensile ruptures of two bolted connections in flat sheets. They are the most straightforward net section tensile rupture mode.



(a) (b)
Figure 1 Net section tensile ruptures in flat sheets

Section E6.2 of the North American Specification for the Design of Cold-formed Steel Structural Members (AISI 2012) specifies the tensile rupture resistance of a connection with a single bolt or a single row of bolts perpendicular to the force, such as that shown in Figure 1(a), to be

$$R_n = A_n F_u \left(k \frac{d}{s} \right) \leq A_n F_u \quad (1)$$

in which A_n is the net area of the connected part, F_u is the material tensile strength of the connected part, d is the nominal bolt diameter, and s is the sheet

width divided by the number of bolt holes in the cross-section considered. The term $k(d/s)$ represents the in-plane shear lag factor.

The coefficient k is equal to 4.15 for the inside sheet of a double-shear connection, 2.5 for the outside sheet of a double-shear connection or for a single-shear connection without washers, and 3.33 when washers are used for the outside sheet of a double-shear connection or for a single-shear connection.

Teh & Gilbert (2012) have shown that Equation (1) wrongly implies that, for practical bolted connections, the tensile rupture resistance R_n would increase with increasing bolt (hole) diameter, contrary to rational expectation and laboratory test results. For a single-bolt connection, where the variable s equals the sheet width W and the net section area A_n approximates $(W - d)t$, the variation of the tensile rupture resistance R_n with respect to the bolt diameter d is, according to Equation (1)

$$\left(\frac{\partial R_n}{\partial d}\right)_{(1)} = tF_u k \left(1 - \frac{2d}{W}\right) \quad (2)$$

Equation (2) means that, for a given sheet width W , the predicted tensile rupture resistance R_n would only decrease with increasing bolt (hole) diameter d if W is less than $2d$. On the other hand, in practice, the sheet width W is typically equal to three times the bolt diameter d , if not greater.

The anomaly inherent in the form of Equation (1) is illustrated numerically in Table 1. The sheet width W of both single-shear connections is equal to 50 mm. Since the material and the sheet thickness are the same, the specimen having the bolt hole diameter of 13 mm must have a higher tensile rupture resistance than the one with a bolt hole diameter of 17 mm by virtue of the former's greater net section area. However, Equation (1) wrongly predicts the opposite.

Table 1 Anomaly of Equation (1) for single-shear connections without washers

Spec	W (mm)	d_h (mm)	d (mm)	A_n	$2.5 d/s$	R_n , Eqn (1)
1	50	13	12	$37 t$	0.6	$22.2 tF_u$
2	50	17	16	$33 t$	0.8	$26.4 tF_u$

Teh & Gilbert (2012) also found that the in-plane shear lag factor implied by Equation (1) for the inside sheet of a double-shear connection never came into effect for their test specimens which failed in the net section tensile rupture

mode. The coefficient k of 4.15 for such specimens resulted in a shear lag factor greater than unity, which had to be artificially neglected in the calculation.

Based on the test results of Teh & Gilbert (2012) for double-shear and single-shear connection specimens, the following equation has been proposed without discrimination of the connection types

$$R_n = A_n F_u \left(0.9 + 0.1 \frac{d}{s} \right) \quad (3)$$

Equation (3) does not suffer from the anomaly of Equation (1), and never implies a shear lag factor greater than unity.

Equation (3) was checked against the double-shear and single-shear (with and without washers) test results of Teh & Gilbert (2012) and Rogers & Hancock (1997), comprising sixty two G300, G450 and G550 sheet steel specimens. The G300 sheet steel is the most ductile, with an average elongation over a 50-mm gauge length of about 25% and a ratio of tensile strength F_u to yield stress F_y being as high as 1.18. The G550 sheet steel is the least ductile, with the elongations ranging from 1% to 6% and the F_u/F_y ratio equal to 1.00.

The authors did not find any noticeable differences in the net section efficiency of the flat sheets among the G300, G450 and G550 steel specimens tested by Teh & Gilbert (2012) and Rogers & Hancock (1997), nor between the double-shear and single-shear specimens.

The overall mean professional factor of Equation (3) was found to be 1.04 with a coefficient of variation equal to 0.041, as shown in Table 2. The performance of the proposed equation is superior to that of the current AISI specification's Equation (1), especially for the single-shear specimens.

Table 2 Results of Equations (1) and (3)

Connection Type	N	Eqn (1), AISI		Eqn (3), Proposed	
		Mean	COV	Mean	COV
Double-shear	28	0.95	0.031	1.02	0.030
Single-shear with washers	31	1.31	0.116	1.05	0.045
Single-shear without washers	3	1.34	0.137	1.03	0.018
Overall	62	1.15	0.188	1.04	0.041

In order to attain the target reliability index β_o of 3.5 for cold-formed steel connections (AISI 2012) using the proposed Equation (3), the resistance factor ϕ was computed to be 0.75 in accordance with Section F1.1 of the specification (AISI 2012). If the existing resistance factor of 0.65 is used, then the resulting reliability index β of Equation (3) will be 4.1.

Tensile rupture resistance of a channel brace bolted at the web

Figure 2 shows the net section tensile ruptures of two channel braces bolted at the web. It may be noted that the snug-tightening of the downstream bolt in specimen CSS7 did not affect the tensile rupture resistance of the bolted connection, which fractured at the upstream bolt hole (Teh & Yazici 2013).

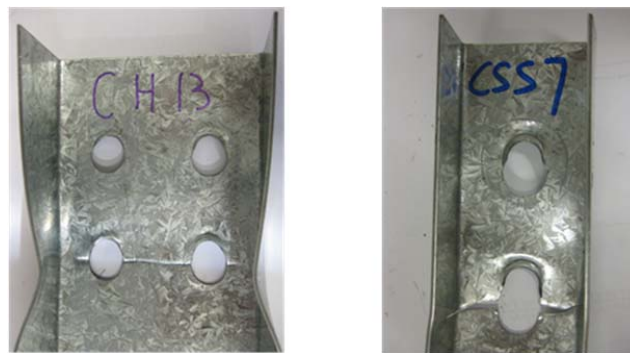

Figure 2 Net section tensile ruptures of channel braces bolted at the web

Section E6.2 of the North American Specification for the Design of Cold-formed Steel Structural Members (AISI 2012) specifies the tensile rupture resistance of a channel brace bolted at the web to be

$$R_c = A_n F_u \max \left\{ 0.5, \min \left(0.9, 1 - 0.36 \frac{\bar{x}}{L} \right) \right\} \quad (4)$$

in which \bar{x} is the distance between the connection interface and the section's centroid in the direction normal to the connection plane, and L is the connection length. These two variables are defined in Figure 3.

The end distance of 50 mm shown in Figure 3 was used by Teh & Gilbert (2013a) to avoid the block shear and shear-out failure modes. However, if the gauge (i.e. the distance between the bolts in the direction perpendicular to loading) is too small, then the block shear failure mode would still be possible.

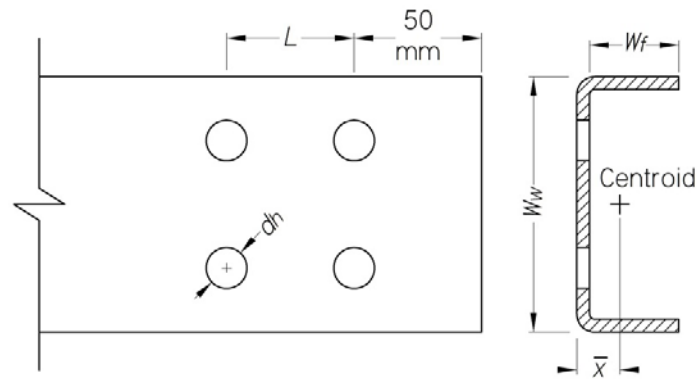

Figure 3 Geometric variables of a channel brace bolted at the web

Equation (4) suggests that, for most practical channel braces, the net section efficiency factor is 0.9 due to the low ratios \bar{x}/L . Table 3 illustrates the implication, which is unlikely to be the intent of the specification.

Table 3 Unintended implication of Equation (4)

W_w (mm)	W_f (mm)	T (mm)	\bar{x} (mm)	L (mm)	$1 - 0.36 \bar{x}/L$ AISI	$1 - \bar{x}/L$ AISC	AISI/ AISC
50	20	1.9	4.34	36	0.96	0.88	1.09
50	30	1.9	8.15	36	0.92	0.77	1.19
75	25	1.9	4.90	36	0.95	0.86	1.10
75	25	1.9	4.90	48	0.96	0.90	1.07
75	40	1.9	10.3	48	0.92	0.79	1.17
75	40	1.9	10.3	60	0.95	0.83	1.13
125	40	2.4	7.64	60	0.95	0.87	1.09
125	50	2.4	11.0	60	0.93	0.82	1.14

It is therefore not surprising that Equation (4) was found to be over-optimistic for specimens tested by various researchers (Maiola et al. 2002, Pan 2004, Teh & Gilbert 2013a, Teh & Yazici 2013), whether snug-tightening of bolts were applied or not.

In any case, Equation (4) ignores the fact that the net section efficiency factor of a channel brace bolted at the web is influenced by the ratio of the flange width to the web depth, in addition to the ratio of the connection eccentricity to the connection length, as found by Pan (2004).

Teh & Gilbert (2013a) proposed the following heuristic equation for determining the tensile rupture resistance of a channel brace bolted at the web with two or more rows of bolts

$$R_c = A_n F_u \left(\frac{1}{1.1 + \frac{W_f}{W_w + 2W_f} + \frac{\bar{x}}{L}} \right) \quad (5)$$

in which W_f is the width of the flange and W_w is the depth of the web.

As the flange width W_f and the connection eccentricity \bar{x} approach zero, i.e. the channel section becoming a flat sheet, the efficiency factor embedded in Equation (5) approaches 0.91, which is a reasonable if conservative approximation as evident from Equation (3). This result is also consistent with the upper bound value of 0.9 implicit in the specification's Equation (4).

The constant of 1.1 in the denominator of Equation (5) accounts for the in-plane shear lag effect in a simple manner, and the term $W_f/(W_w + 2W_f)$ may be considered to account for the out-of-plane shear lag effect of a channel brace bolted at the web. Such out-of-plane shear lag is also present in a bi-symmetric I-section bolted at the flanges only (Munse & Chesson 1963).

While the term \bar{x}/L is commonly referred to as a shear lag factor variable in the literature following the terminology of Munse & Chesson (1963), it is considered in the present work to account for the detrimental bending moment effect due to the connection eccentricity \bar{x} and for the counteracting bending moment effect that increases with the connection length L (Epstein & Aiuto 2002). The effects of \bar{x} and L on the longitudinal normal stresses in the web are illustrated in Figure 4.

Equation (5) was checked against the test results of Teh & Gilbert (2013a), Teh & Yazici (2013) and Pan (2004) for single channel braces bolted at the web, comprising 53 specimens composed of G450 ($F_u/F_y = 1.04$ to 1.09) and SSC400 ($F_u/F_y = 1.37$) sheet steels with aspect ratios (W_f/W_w) ranging from 0.25 to 0.75.

Only specimens which were known to have failed in net section tensile rupture, as described by Teh & Yazici (2013), were included.

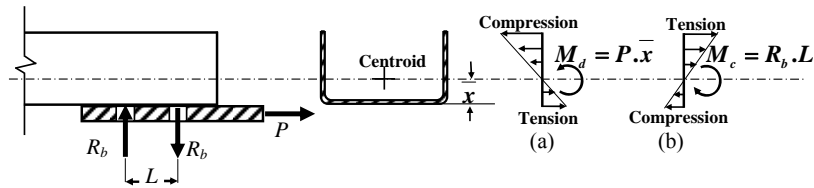

- (a) Detrimental bending moment M_d due to connection eccentricity
- (b) Counter-acting moment M_c from bolt reactions

Figure 4 Effects of connection eccentricity \bar{x} and connection length L

The mean professional factor of Equation (5) was found to be 1.02 with a coefficient of variation equal to 0.067. In order to attain the target reliability index β_o of 3.5 for the proposed Equation (5), the resistance factor ϕ was computed to be 0.73 in accordance with Section F1.1 of the specification (AISI 2012). If the existing resistance factor of 0.65 is used, then the resulting reliability index β of Equation (5) will be 4.0.

Tensile rupture resistance of an angle brace bolted at one leg

Figure 5 shows the net section tensile rupture of an angle brace bolted at one leg. Sixty one specimens were tested by Teh & Gilbert (2013b), the configurations of which comprised single equal angle, single unequal angle bolted at the wider leg, single unequal angle bolted at the narrow leg, double equal angles, and alternate equal angles, as depicted in Figures 6(a) through 6(e).



Figure 5 Net section tensile rupture of an angle brace bolted at one leg

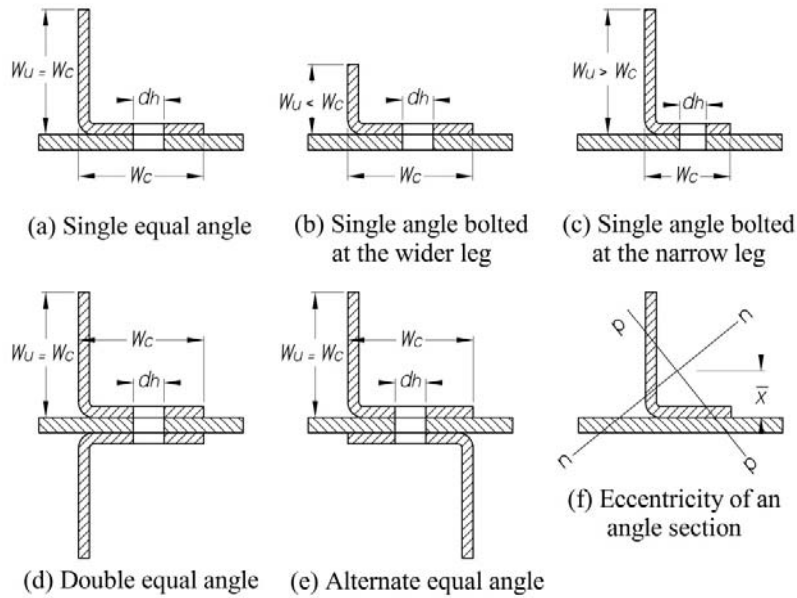

Figure 6 Configurations of angle braces tested by Teh & Gilbert (2013b)

Section E6.2 of the North American Specification for the Design of Cold-formed Steel Structural Members (AISI 2012) specifies the tensile rupture resistance of an angle brace bolted at one leg to be

$$P_p = A_n F_u \max \left\{ 0.4, \min \left(0.9, 1 - 1.2 \frac{\bar{x}}{L} \right) \right\} \quad (7)$$

Equation (7) was found by Maiola et al. (2002), Paula et al. (2008), Prabha et al. (2011) and Teh & Gilbert (2013b) to be over-optimistic. Like Equation (4), it neglects the out-of-plane shear lag effect, which depends on the length ratio of unconnected leg to connected leg.

Teh & Gilbert (2013b) modified Equation (5) to suit an angle brace bolted at one leg

$$P_p = A_n F_u \left(\frac{1}{1.1 + \frac{W_u}{W_c + W_u} + \frac{\bar{x}}{L}} \right) \quad (8)$$

Teh & Gilbert (2013b) did not find significant differences in the net section efficiency among Configurations (a), (b), (d) and (e) shown in Figure 6, for which Equation (8) was found to be reasonably accurate. However, Equation (8) did not perform so well for Configuration (c) depicted in Figure 6.

By inspection, a channel section having an aspect ratio (W_f/W_w) equal to 0.5 should have (about) the same out-of-plane shear lag factor as an equal angle section, since each symmetric half of the channel section is an equal angle. However, the out-of-plane shear lag factor of such a channel section implicit in Equation (5) is 0.25, while that of an equal angle section implicit in Equation (8) is 0.5, or double the value. On the other hand, Teh & Gilbert (2013b) have mentioned that a channel brace has one eccentricity only, i.e. with respect to the web, while an angle brace has two orthogonal eccentricities with respect to both legs. The authors therefore tried the following equation, which was used by Teh & Gilbert (2014) to determine the tensile rupture resistance of an equal angle brace bolted at different legs (see Figure 7)

$$P_p = A_n F_u \left(\frac{1}{1.1 + 0.5 \frac{W_u}{W_c + W_u} + 2 \frac{\bar{x}}{L}} \right) \quad (9)$$

The mean professional factors and coefficients of variation given by Equations (7) and (9) for the six configurations depicted in Figures 6 and 7 are shown in Table 4. In order to attain the target reliability index β_o of 3.5 for the proposed Equation (9), the resistance factor ϕ was computed to be 0.72 in accordance with Section F1.1 of the specification (AISI 2012). If the existing resistance factor of 0.65 is used, then the resulting reliability index β of Equation (9) will be 3.9.

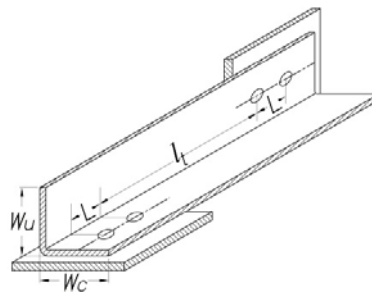

Figure 7 Equal angle brace bolted at different legs ($W_u = W_c$)

Table 4 Results of Equations (7) and (9)

Configuration	N	Equation (7), AISI		Equation (9), Proposed	
		Mean	COV	Mean	COV
Figure 6 (a)	21	0.76	0.076	0.99	0.046
Figure 6 (b)	14	0.74	0.033	0.97	0.039
Figure 6 (c)	12	0.87	0.115	1.00	0.059
Figure 6 (d)	9	0.74	0.077	0.96	0.052
Figure 6 (e)	5	0.78	0.077	1.02	0.051
Figure 7	10	0.82	0.072	1.03	0.047
Overall	71	0.78	0.099	0.99	0.051

Tensile rupture resistance of a staggered bolted connection

Figure 8 shows the definitions of sheet width W , bolt hole diameter d_h , connection gauge g and bolt stagger s_t for a staggered bolted connection. This type of connection in cold-reduced steel sheets has been experimentally studied by Holcomb et al. (1995), Fox & Schuster (2010) and Teh & Clements (2012). The latter pointed out that the AISI specification's equation for a staggered bolted connection neglects a certain term of Cochrane's original formula.

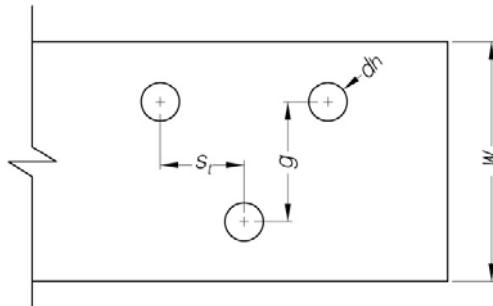

Figure 8 A staggered bolting pattern

The original Cochrane's formula for the net width is (Cochrane 1922)

$$W_{\text{net}} = W - \max \left(n_n d_h, n_s d_h - \sum \frac{s_t^2}{4g + 2d_h} \right) \quad (10)$$

in which n_n is the number of unstaggered bolts in the considered section ($n_n = 1$ in Figure 8) and n_s is the number of staggered bolts in the considered section ($n_s = 2$ in Figure 8).

Teh & Clements (2012) have pointed out that the neglect of the term “ $2d_h$ ” in the AISI specification’s equation does not simplify the formula in a meaningful way, while the neglect can lead to overestimations of about 10% even though the instances may be rare in practice. The current specification’s equation results in a mean profession factor of 0.89 with a coefficient of variation equal to 0.044 for the 76 specimens tested by Teh & Clements (2012) and the authors, which had very wide ranges of stagger s_t and gauge g .

If Equation (10) is used in conjunction with the reduction factor of 0.9 proposed by LaBoube & Yu (1996), then a mean professional factor of 1.00 with a coefficient of variation equal to 0.048 will be obtained. In order to attain the target reliability index β_o of 3.5 for Equation (10), the resistance factor ϕ was computed to be 0.72 in accordance with Section F1.1 of the specification (AISI 2012). If the existing resistance factor of 0.65 is used, then the resulting reliability index β of Equation (9) will be 3.9.

Conclusions

The AISI specification’s equation for determining the tensile rupture resistance of a bolted connection in a flat sheet leads to an anomaly, that a bolted connection with a reduced net section area had a greater resistance. For single-shear connections, the code equation is excessively conservative (over 30%). In contrast, the design equation proposed in this paper does not suffer from the anomaly, and has been demonstrated to be consistently accurate for double-shear and single-shear connections composed of steel materials having very different levels of ductility.

The AISI specification’s equation for determining the tensile rupture resistance of a channel brace bolted at the web implies a net section efficiency factor of 0.9 for practical channel braces, and is therefore over-optimistic. The design equation proposed in this paper has been found to be accurate for channel braces having different aspect ratios and material properties.

The equation previously proposed by the author for determining the tensile rupture resistance of an angle brace bolted at one leg was modified in this paper so that the newly proposed equation is consistently accurate for single equal angle bolted at one leg, single unequal angle bolted at the wider leg, single

unequal angle bolted at the narrow leg, double equal angles, alternate equal angles and single equal angle bolted at different legs.

The 2012 AISI specification's equation for determining the tensile rupture resistance of a staggered bolted connection, which removes the previous reduction factor of 0.9, is over-optimistic for many connections. The proposed equation, which incorporates the term of Cochrane's original formula missing from the specification's equation, has been found to be accurate for staggered bolted connections with very wide combinations of stagger and gauge.

For each of the four equations proposed in this paper, no artificial lower bound or upper bound is used, so the equation is continuous. Each proposed equation is simple and never implies a net section efficiency factor greater than unity.

It is recommended that a uniform resistance factor of 0.70 be applied to all four proposed equations for determining the tensile rupture resistance of bolted connections in cold-formed steel members.

References

- AISI (2010) *Supplement No. 2 to the North American Specification for the Design of Cold-formed Steel Structural Members 2007 Edition*, American Iron and Steel Institute, Washington DC.
- AISI (2012) *North American Specification for the Design of Cold-formed Steel Structural Members 2012 Edition*, American Iron and Steel Institute, Washington DC.
- Cochrane, V. H. (1922) "Rules for rivet hole deductions in tension members." *Engrg. News Record*, Vol. 80, November.
- Epstein, H. I., and Aiuto, C. L. D. (2002) "Using moment and axial interaction equations to account for moment and shear lag effects in tension members." *Engrg. J. AISC*, 39 (2), 91-99.
- Fox, D. M., and Schuster, R. M. (2010) "Cold formed steel tension members with two and three staggered bolts," *Proc., 20th Int. Specialty Conf. Cold-Formed Steel Structures*, St Louis, MO, 575-588.
- Holcomb, R. D., LaBoube, R. A., and Yu, W. W. (1995) "Tensile and bearing capacities of bolted connections," *Second Summary Report, Civil Engineering Study 95-1, Cold-Formed Steel Series*, Dept. of Civ. Engrg., Center for Cold-Formed Steel Structures, University of Missouri-Rolla.
- LaBoube, R.A. (1988). "Strength of bolted connections: Is it bearing or net section?," *Proc., 9th Int. Specialty Conf. Cold-Formed Steel Structures*, St Louis, MO, 589-601.

- LaBoube, R. A., and Yu, W. W. (1996) "Additional design considerations for bolted connections," *Proc., 13th Int. Specialty Conf. Cold-Formed Steel Structures*, St Louis, MO, 575-593.
- Maiola, C. H., Malite, M., Goncalves, R. M., and Neto, J. M. (2002) "Structural behaviour of bolted connections in cold-formed steel members, emphasizing the shear lag effect," *Proc., 16th Int. Specialty Conf. Cold-Formed Steel Structures*, Orlando, FL, 697-708.
- Munse, W. H., and Chesson, E. (1963) "Riveted and bolted joints: Net section design," *J. Struct. Div. ASCE*, 89 (ST1), 107-126.
- Pan, C. L. (2004) "Prediction of the strength of bolted cold-formed channel sections in tension," *Thin-Walled Struct.*, 42, 1177-1198.
- Prabha, P., Jayachandran, S. A., Saravanan, M., and Marimuthu, V. (2011) "Prediction of the tensile capacity of cold-formed angles experiencing shear lag," *Thin-Walled Struct.*, 49, 1348-1358.
- Paula, V. F., Bezerra, L. M., and Matias, W. T. (2008) "Efficiency reduction due to shear lag on bolted cold-formed steel angles," *J. Construct. Steel Res.*, 64, 571-583.
- Rogers, C. A., and Hancock, G. J. (1997) "Bolted connection tests of thin G550 and G300 sheet steels." *Res. Rep. No. R749*, Dept. of Civ. Engrg., University of Sydney, Australia.
- Rogers, C. A., and Hancock, G. J. (2000) "Failure modes of bolted-sheet-steel connections loaded in shear." *J. Struct. Eng.*, 126 (3), 288-296.
- Teh, L. H., and Clements, D. D. A. (2012) "Tension capacity of staggered bolted connections in cold-reduced steel sheets." *J. Struct. Eng.*, 138 (6), 769-776.
- Teh, L. H., and Gilbert, B. P. (2012) "Net section tension capacity of bolted connections in cold-reduced steel sheets." *J. Struct. Eng.*, 138 (3), 337-344.
- Teh, L. H., and Gilbert, B. P. (2013a) "Net section tension capacity of cold-reduced sheet steel channel braces bolted at the web." Special Issue on Cold-Formed Steel Structures, *J. Struct. Eng.*, 139 (5), 740-747.
- Teh, L. H., and Gilbert, B. P. (2013b) "Net section tension capacity of cold-reduced sheet steel angle braces bolted at one leg." *J. Struct. Eng.*, 139 (3), 328-337.
- Teh, L. H., and Gilbert, B. P. (2014) "Net section tension capacity of equal angle braces bolted at different legs." *J. Struct. Eng.*, 06014002, published online 18 February 2014.
- Teh, L. H., and Yazici, V. (2013) "Shear lag and eccentricity effects of bolted connections in cold-formed steel sections." *Eng. Struct.*, 52, 536-544.
- Yip, A. S. M., and Cheng, J. J. R. (2000) "Shear lag in bolted cold-formed steel angles and channels in tension," *Struct. Engrg. Report No. 233*, Dept. Civ. & Env. Engrg., University of Alberta, Edmonton, Canada.